

Technical Information

Power
12V (battery operation offers increased flexibility on installation)
2 years battery life in normal operation
LEDs
2x Red Flashing Indicator strips (40 Seconds after impact)
Brightness: 68lm/M

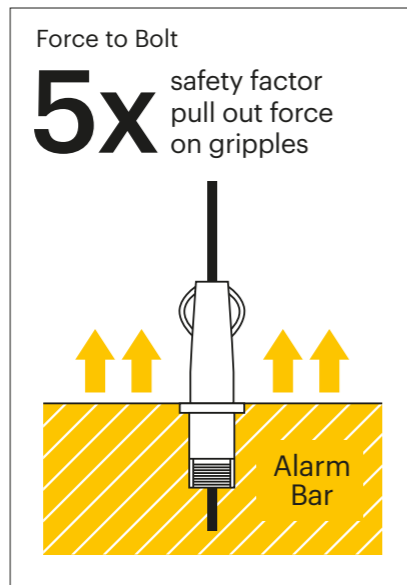

Material Properties	MEMAPLEX™
Temperature Range	+41°F to 122°F
Ignition Temperature	698°F to 734°F
Flash Point	662°F to 698°F
Toxicity	Not Hazardous
Chemical Resistance	Excellent - ISO/TR 10358
Weathering Stability (Grey Scale)	5/5*
Light Stability (Blue Wool Scale)	7/8**
Static Rating (Surface Resistivity)	1015 - 1016 Ω
Hygiene Seals	No

* Weathering scale 1 is very poor and 5 is excellent
 ** Light stability scale 1 is very poor and 8 is excellent

Audio & Visual Alerts

Level per buzzer:

2x Buzzers per Alarm Bar

102dB*

20 seconds after impact

40 seconds after impact

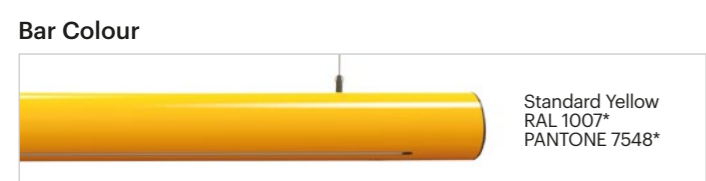
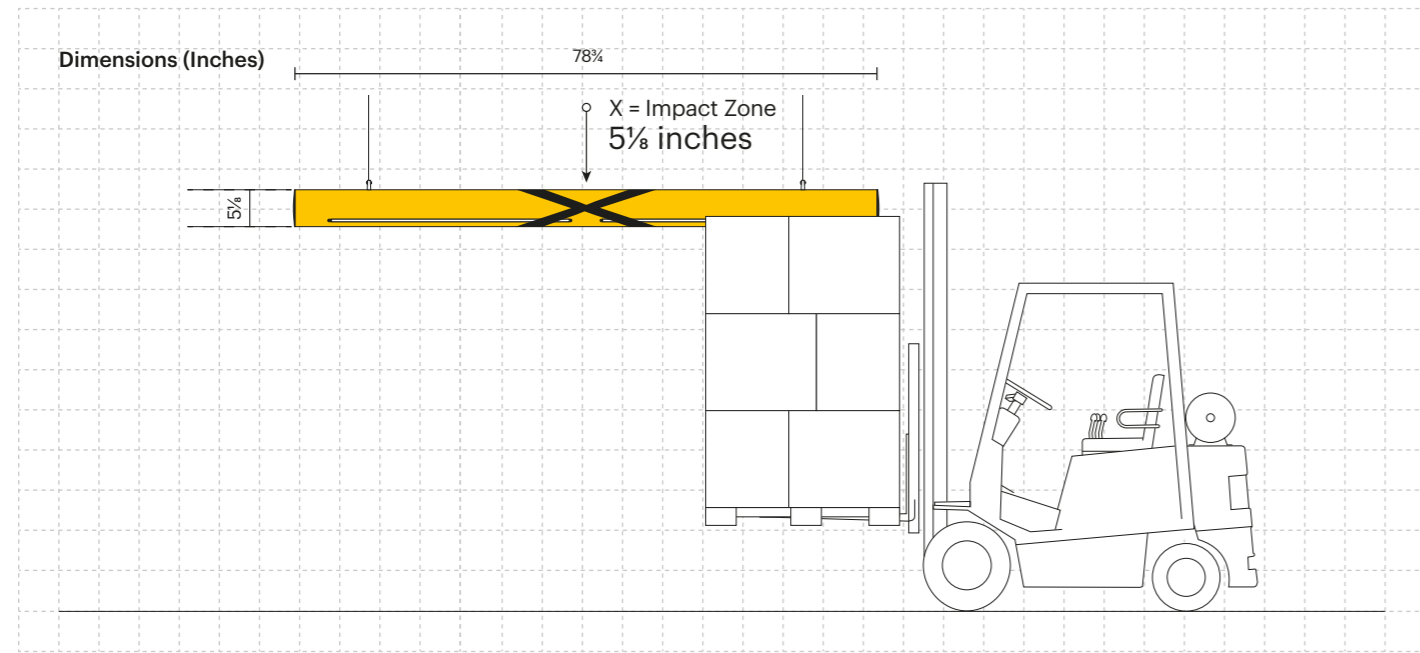

Colour Combinations

*Please note that the RAL and PANTONE colours listed are the closest match to standard A-SAFE colours, but may not be exact matches of the actual product colour and should be used for guidance only.

* Based on sound measured at a distance of 10 cm from sound port in an environment with 73.3 dB of ambient noise. Detected sound levels vary by distance and position of SPL meter in relation to sound ports.



Alarm Bar



Designed to protect overhead assets from accidental damage from moving vehicles.

This ceiling-mounted barrier provides audible and visible alarms to prevent damage before it happens, averting vehicle impacts and changing driver behavior over time.

Quick and easy to install, it can be used to safeguard doorframes, loading docks, infrastructure and overhead walkways, as well as key safety assets such as sprinkler systems and ventilation pipes.



Your Authorized A-SAFE Distributor
 856-687-2227 • sales@banksindustrial.com • BanksIndustrial.com
 PO Box 382 • Berlin, NJ 08009

Engineered for performance

Whether in the resilience, flexibility and in-built memory of our exclusive Memaplex™ material or the unrivalled energy absorption of our unique 3-phase coupling system, a wealth of technical ingenuity goes into every A-SAFE product to ensure that it performs perfectly every time you need it to. We are continuously innovating to solve the greatest workplace safety challenges on behalf of our customers and our numerous patents attest to our industry-leading commitment to research and development.

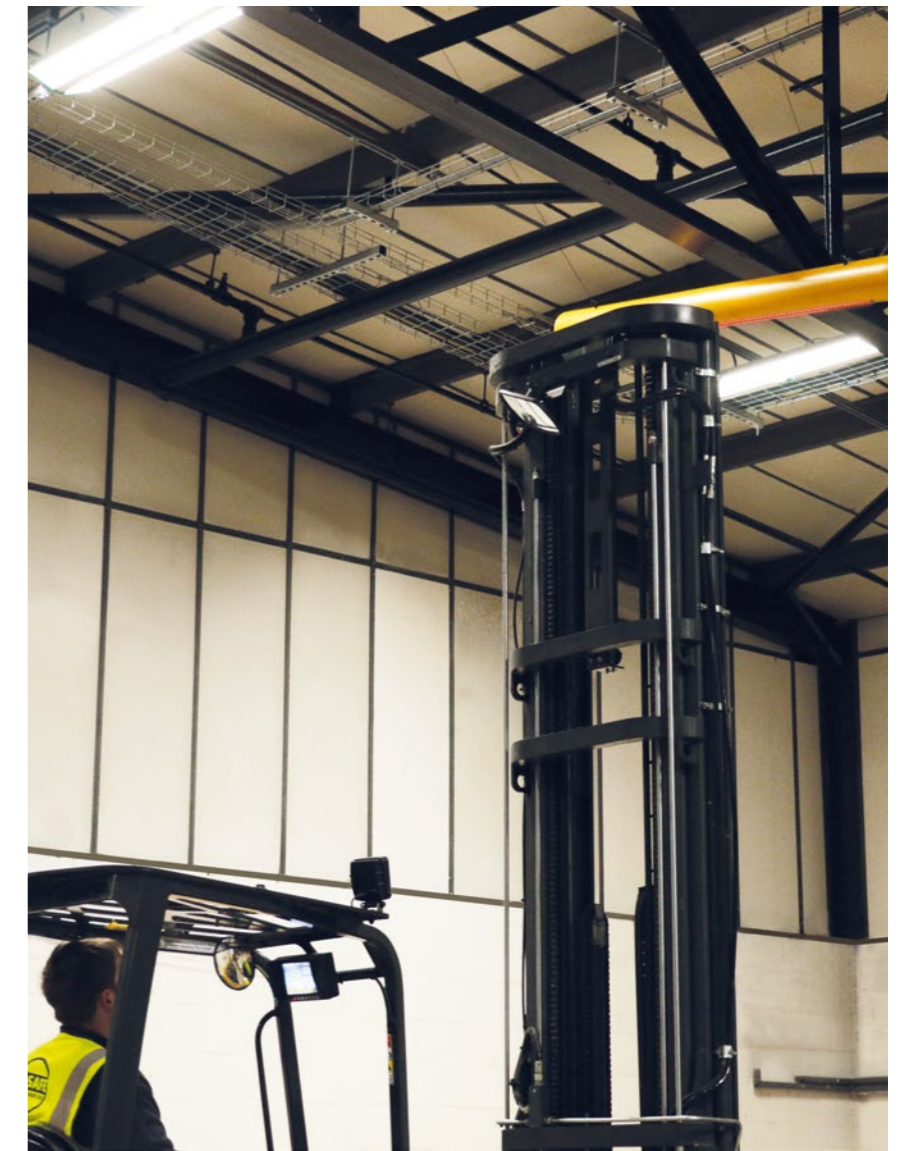
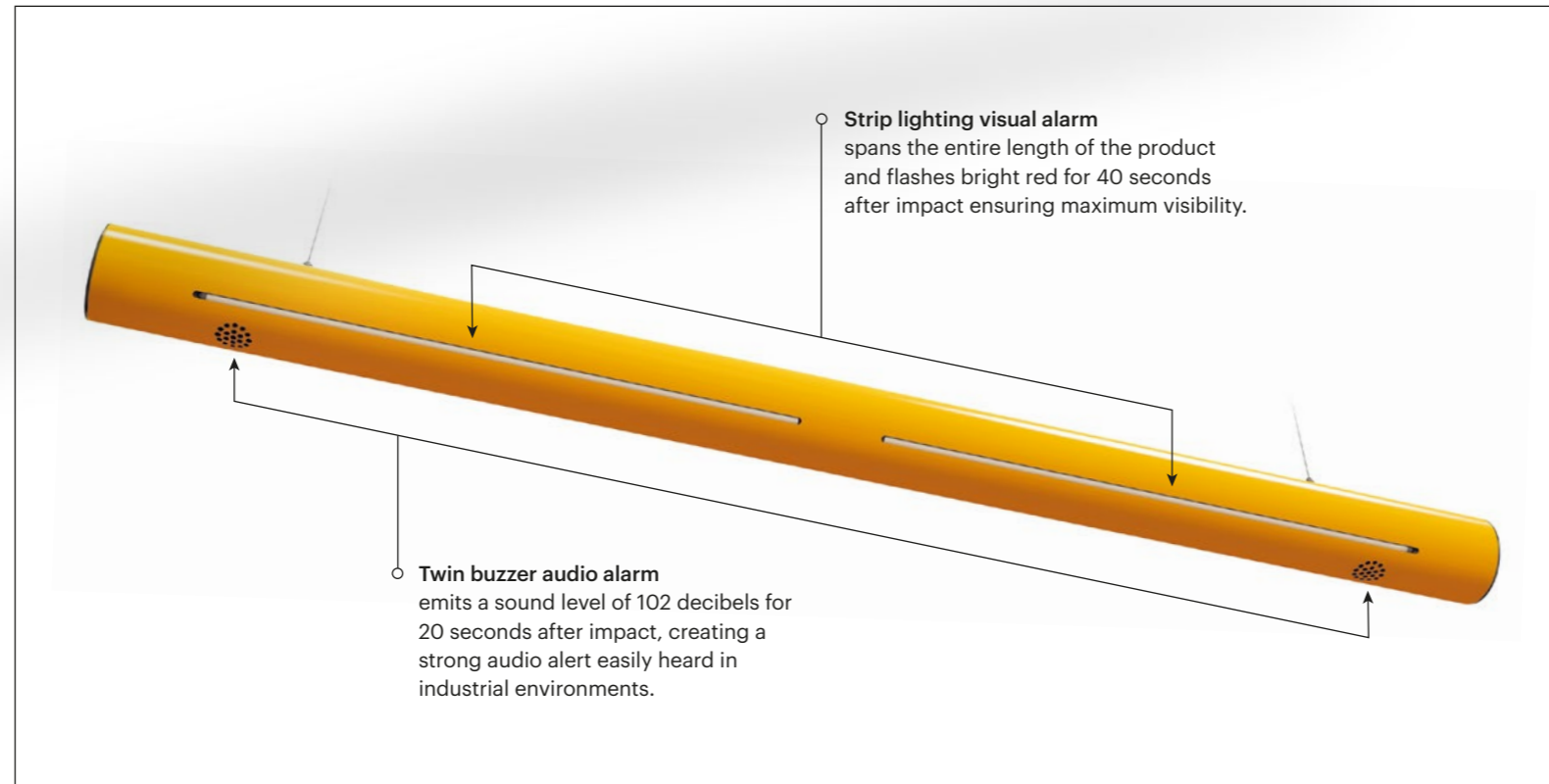
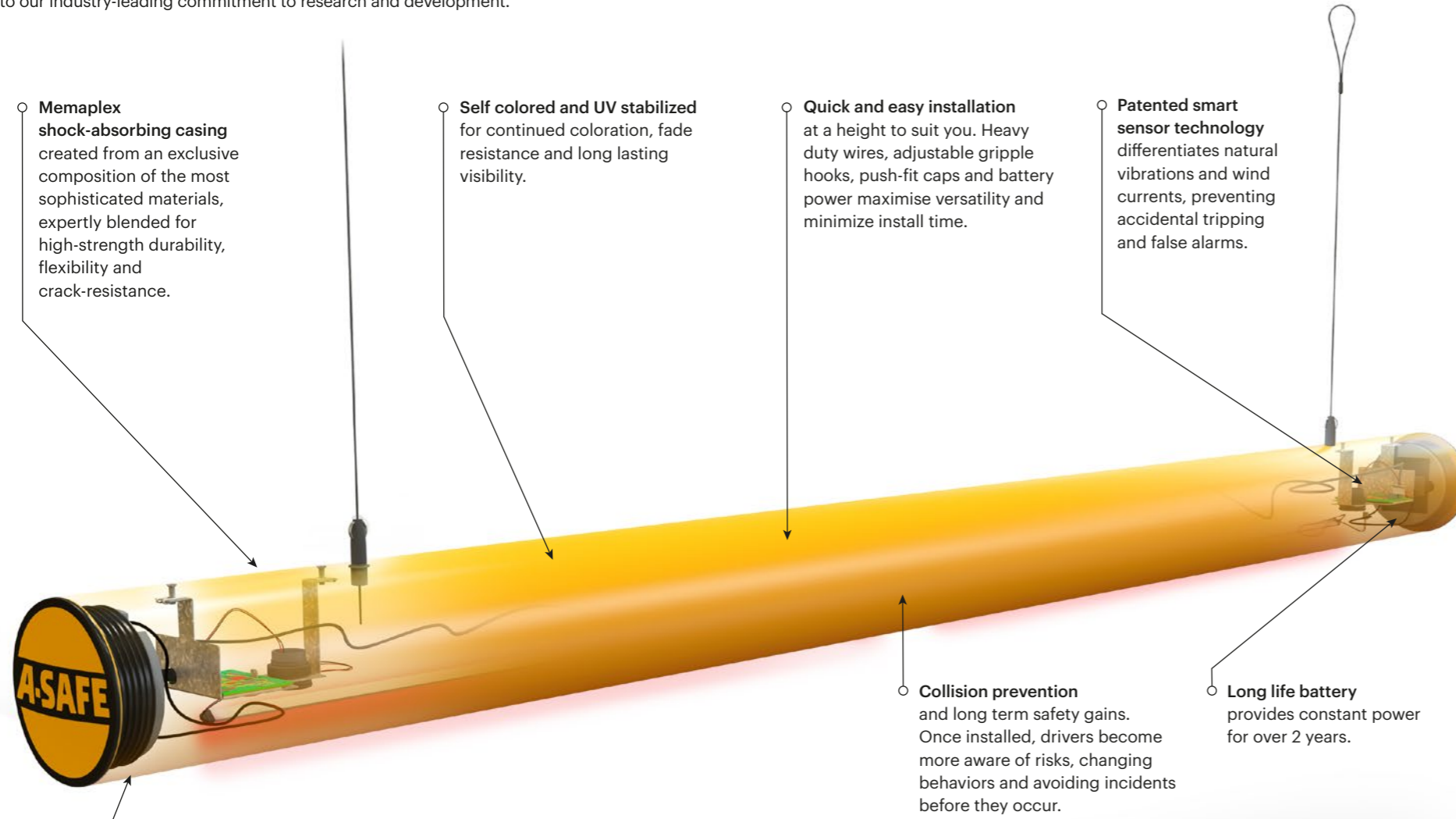

Protect low hanging infrastructure in environments where high-level vehicles such as forklift trucks are in operation.



Twin buzzers each emit a 102 decibel alarm for 20 seconds, the equivalent of a car horn 1 meter away. Simultaneously, indicator strips flash bright red for 40 seconds, creating a complete and powerful audio-visual alert.