



iFlex™

Slide Gate

A-SAFE



Slide Gates provide access openings for pedestrians and vehicles at certain points within guardrail sections.

The gate creates a physical stop to prevent pedestrians and drivers travelling straight through a gap or crossing point. The telescopic sliding motion optimises space and can remain open; ideal for vehicle entry and exit into areas.

Compatible with all Pedestrian Guardrails and combined Pedestrian and Traffic Guardrails, they can be installed on their own or in pairs to increase the size of the opening.

Compliant to the global benchmark in guardrail safety

bsi. PAS 13

Code of Practice for Workplace Safety Guardrails



**BANKS
INDUSTRIAL
GROUP**

Your Authorized A-SAFE Distributor

856-687-2227 • sales@banksindustrial.com • BanksIndustrial.com

PO Box 382 • Berlin, NJ 08009

Engineered for performance

Memaplex™ advanced polymer created from an exclusive composition of the most sophisticated polyolefins and rubber additives, expertly blended for unequalled durability.

Ultra-low maintenance material is chemical and water resistant, non-corrosive, non-scratch and self colored so no repainting, rusting, flaking or corrosion.

Self colored and UV stabilized for continued high visibility and long lasting aesthetics with no repainting.

Space optimisation and zero route obstruction when gate is open, enabled by telescopic slide operation.

Stay-open function Enables fluid traffic flow when route access is needed for a prolonged period of time.

Ergonomic design with no sharp edges.

Environmentally friendly and 100% recyclable.

Zinc nickel, electrophoretic coating on base plates as standard, provides advanced protection against corrosion damage.

Twin-gate option allows the gate to be installed in pairs to provide a maximum opening of 157½ inches.

ADDITIONAL BASE OPTIONS

- Countersunk Bolts
- Galvanized Steel
- Stainless Steel 316 Standard
- Stainless Steel 316 Countersunk

Technical Information

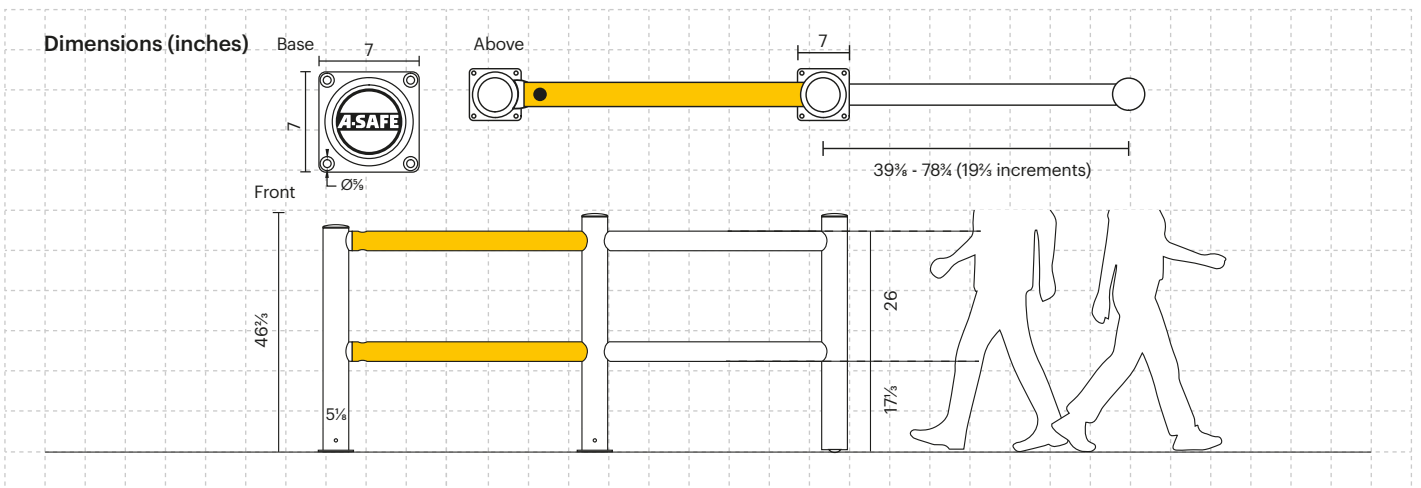

Post Options

	Standard Black RAL 9005* PANTONE Black		Standard Yellow RAL 1007* PANTONE 7548*
--	----------------------------------------------	--	-----------------------------------------------

Rail Option

	Standard Black RAL 9005* PANTONE Black
--	----------------------------------------------

Color Combinations

*Please note that the RAL and PANTONE colors listed are the closest match to standard A-SAFE colors, but may not be exact matches of the actual product color and should be used for guidance only.



Your Authorized A-SAFE Distributor
 856-687-2227 • sales@banksindustrial.com • BanksIndustrial.com
 PO Box 382 • Berlin, NJ 08009