

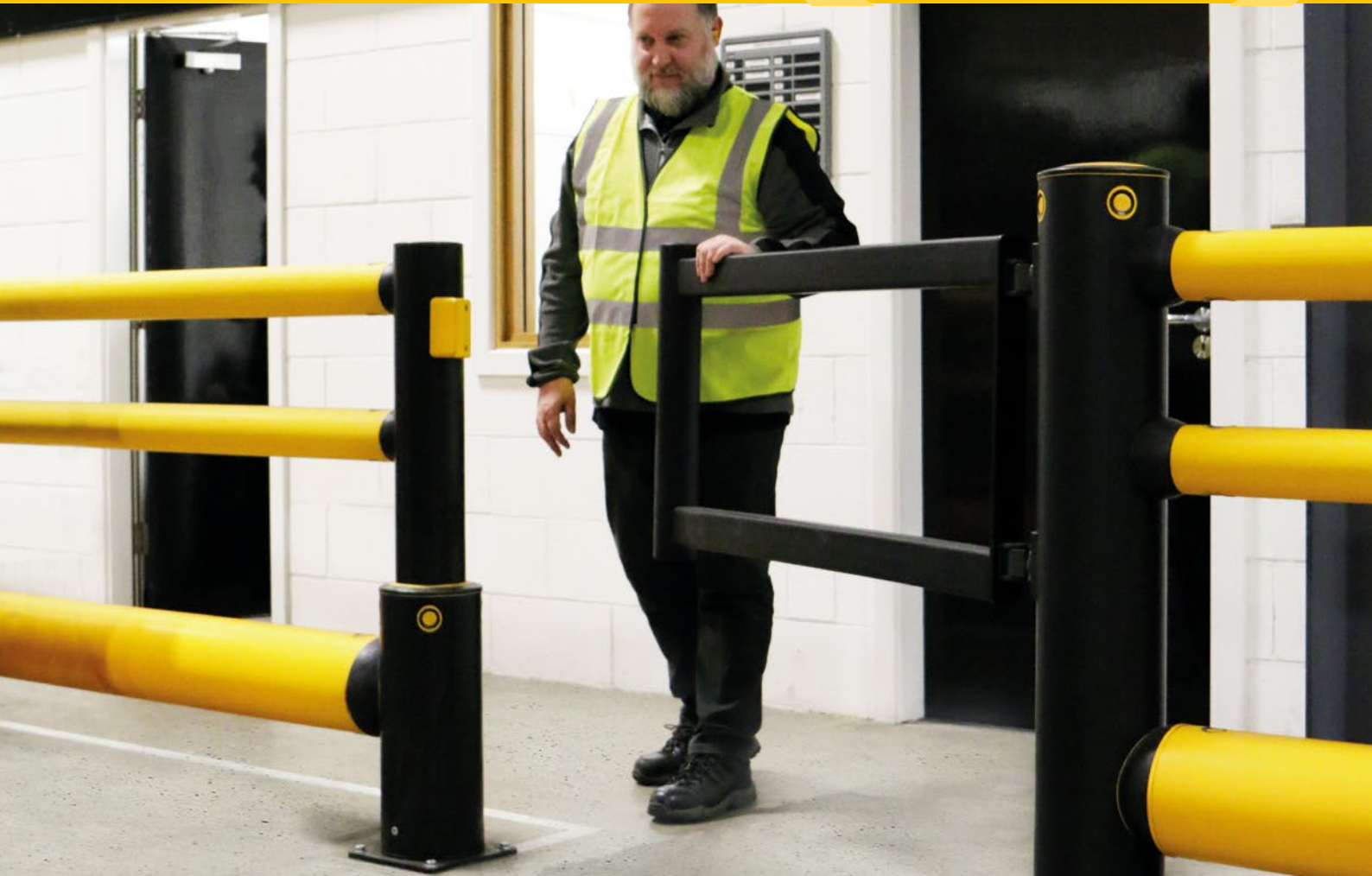

iFlex™

Swing Gate

A-SAFE



Swing Gates provide access and exit points for pedestrians. Available in two lengths, long and short.

The short gate has a hydraulic self-close feature to automatically return the gate to its closed position and maintain pedestrian safety. The long gate is supplied with additional post support for enhanced strength and stay-open access option for both pedestrians and vehicles.

Each gate has a double swing action, but are also supplied with gate stops to limit movement to one direction, forcing pedestrians to hesitate and pull the gate towards them. If desired, can be installed in pairs to increase the size of the opening.

Compliant to the global benchmark in guardrail safety

bsi. PAS 13

Code of Practice for Workplace Safety Guardrails



**BANKS
INDUSTRIAL
GROUP**

Your Authorized A-SAFE Distributor

856-687-2227 • sales@banksindustrial.com • BanksIndustrial.com
PO Box 382 • Berlin, NJ 08009

Engineered for performance

- Double swing action
- Gate stops included as standard
- Safety green available indicating access points for fire exits, fire and safety equipment or medical assistance. It can be easily seen, especially in a long run of yellow guardrail.
- Zinc nickel, electrophoretic coating on base plates as standard, provides advanced protection against corrosion damage.
- Ergonomic design with no sharp edges.
- Environmentally friendly and 100% recyclable.

Memaplex™ advanced polymer
created from an exclusive composition of the most sophisticated polyolefins and rubber additives, expertly blended for unequalled durability.

Varying lengths
to fit any facility. The Short Swing Gate is available from 31½ to 47¼ in 4 inch increments. The Long Swing Gate is available for larger openings up to 78¾ inches.

Swing Gate (Short)
Hydraulic self-close feature automatically returns the gate to its closed position after use to maintain safety.

Swing Gate (Long)
Extended gate length with additional post support for enhanced strength and stay-open access option.

Twin-gate option
allows the gate to be installed in pairs to provide a maximum opening of 94½ inches for the Short Swing Gate and 157½ inches for the Long Swing Gate.

ADDITIONAL BASE OPTIONS

- Countersunk Bolts
- Galvanized Steel
- Stainless Steel 316 Standard
- Stainless Steel 316 Countersunk

Technical Information

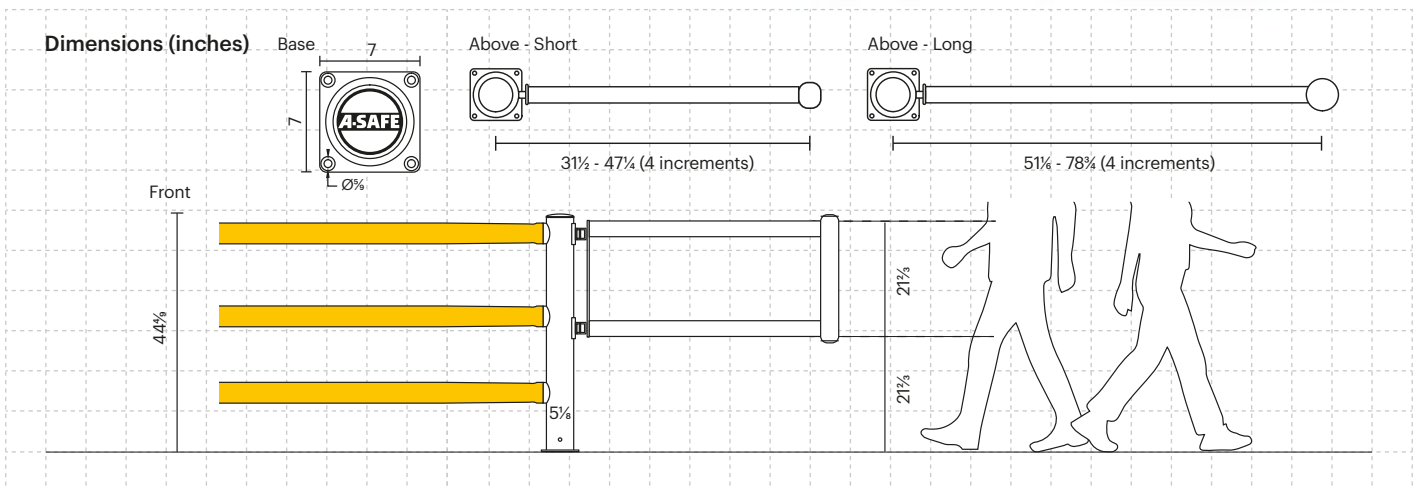

Post Options

	Standard Black RAL 9005* PANTONE Black		Standard Yellow RAL 1007* PANTONE 7548*
--	--	--	---

Rail Options

	Standard Black RAL 9005* PANTONE Black		Standard Green RAL 6032* PANTONE 356*
--	--	--	---

Color Combinations

*Please note that the RAL and PANTONE colors listed are the closest match to standard A-SAFE colors, but may not be exact matches of the actual product color and should be used for guidance only.



Your Authorized A-SAFE Distributor
856-687-2227 • sales@banksindustrial.com • BanksIndustrial.com
PO Box 382 • Berlin, NJ 08009